

## VENT PRO S - EXPLOSION VENTING DEVICE



It is a safety device designed to relieve and release an explosion that might occur inside the protected equipment, where there is an environment with a risk of explosion. Under normal operating conditions, the relief area on the protected equipment is covered by VENT PRO S. If the  $p_{stat}$  is exceeded during an explosion inside the equipment, VENT PRO S will open, thus releasing the pressure from the jeopardized area. The equipment will be exposed to a pressure lower than its pressure resistance.

This data sheet describes the technical parameters of VENT PRO S devices, which have a single-layer convex construction, which include an integrated frame and an optional integrated flange seal. They are suitable for applications with cyclic vacuum loads. They are manufactured in a rectangular design and comply with the standard EN 14 797, NFPA 68 and European Directive 2014/34 / EU.

### CLASSIFICATION

Equipment group	II
Explosive atmosphere	G, D
Equipment category, indoor/outdoor	1/2G, 1/2D
Operating temperature	-40 °C to 100 °C or to 230 °C depending on the seal material
Storage temperature	-10 °C to 40 °C
Standard static opening pressure*	10 kPa ±15%

\* Can also be supplied with a different static opening pressure from 1.5 kPa

### MATERIAL

VENT PRO S	stainless steel
------------	-----------------

### OPTIONAL ACCESSORIES

Opening indicator	cable (G1), magnetic (G2), additional (G3) or induction (G4)
Intrinsically safe relay	It is used to create the interface between the safe and dangerous zone
Integrated flange seal	EPDM, silicon
Thermal insulation	synthetic rubber-based foam
Fasteners	screws - (strength 8.8 or A2-70), nuts ISO 4032, washers ISO 7089 (all in galvanized finish or stainless-steel design)

## DIMENSIONAL DIAGRAM

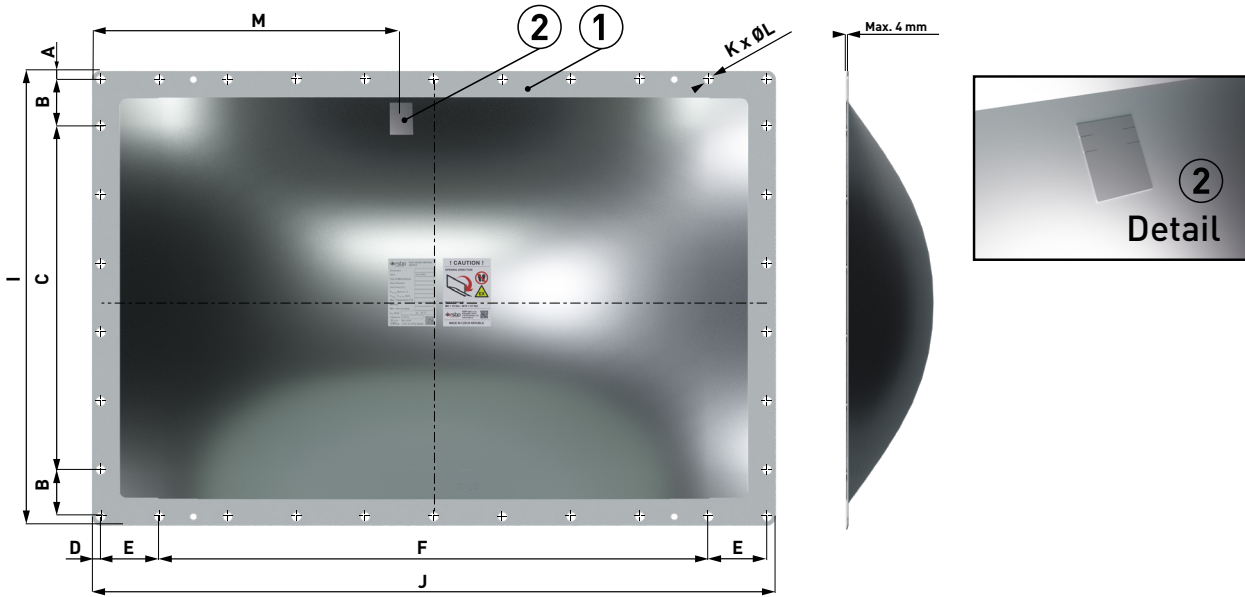

## INSTALLATION VARIANTS

Installing with bolts

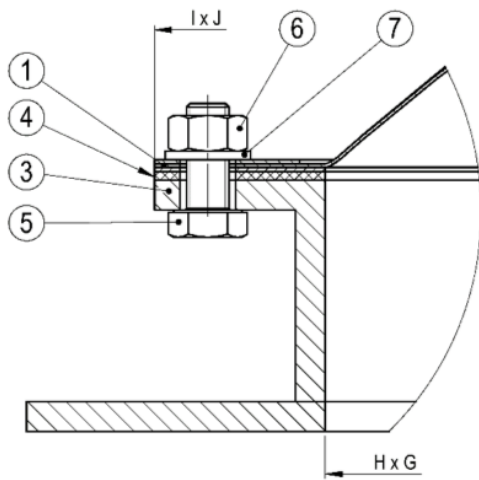

Installing with welded screws

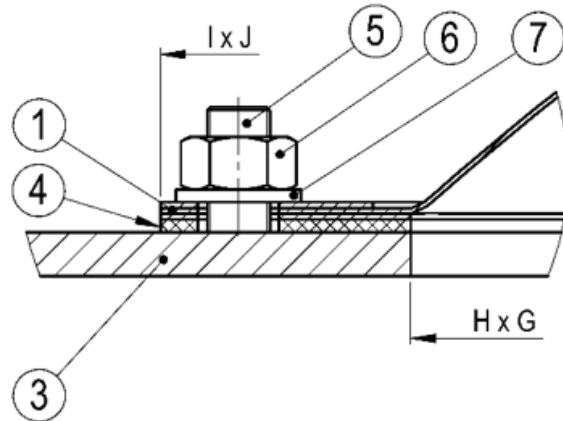

Position	Components	Quantity
①	VENT PRO S	1
②	opening indicator plate VENT PRO	1
③	protected equipment <sup>1)</sup>	1
④	flange gasket (can be integrated in VENT PRO S)	
⑤	screw <sup>2)</sup>	see <sup>3)</sup>
⑥	nut <sup>2)</sup>	see <sup>3)</sup>
⑦	washer <sup>2)</sup>	see <sup>3)</sup>

<sup>1)</sup> The flange of the protected installation device VENT PRO S must meet the requirements of EN ISO 13920-BE and must be sufficiently rigid. In case of mounting on insufficiently rigid equipment, it is necessary to provide the flange with additional reinforcement.

The diameters of the holes in the flange of the protected device for M10 screws are  $\varnothing 12$  mm (EN 20273).

<sup>2)</sup> Fasteners galvanized (strength 8.8) or stainless steel (strength A2-70).

<sup>3)</sup> Number according to the table of technical parameters.

Installation Note:

If the VENT PRO S is not equipped with an integrated flange seal, it is necessary to use another suitable flange seal or sealant to seal the area between the VENT PRO S and the technology flange.

## TECHNICAL PARAMETERS

Dimension	Vent area [m <sup>2</sup> ]	Hole dimension in equipment H x G [mm]	Outer diameter I x J [mm]	A [mm]	B [mm]	C [mm]		D [mm]	E [mm]	F [mm]		Screws/Holes in the VENT PRO		M [mm]	Max. vacuum [bar]
						Number of holes	Spacing			Number of holes	Spacing	K	ØL [mm]		
<b>150x600</b>	0.09	150x600	220x670	12.5	65.0	2	65.0	13.0	92.0	6	92.0	20	335.0	-0.15	
<b>220x540</b>	0.12	220x540	300x620	16.0	90.0	2	88.0	16.0	98.0	5	98.0	18	359.0	-0.35	
<b>229x229</b>	0.05	229x229	309x309	14.5	93.0	2	94.0	14.5	93.0	2	94.0	12	154.5	-0.35	
<b>260x260</b>	0.07	260x260	340x340	16.0	103.0	2	102.0	16.0	103.0	2	102.0	12	170.0	-0.35	
<b>305x457</b>	0.14	300x452	390x542	9.5	76.0	3	102.0	10.0	102.0	4	101.0	18	263.5	-0.35	
<b>340x440</b>	0.15	340x440	400x500	13.0	93.5	3	93.5	13.0	118.5	3	118.5	16	309.3	-0.35	
<b>450x800</b>	0.36	450x800	530x880	15.0	125.0	3	125.0	15.0	110.0	6	126.0	22	440.0	-0.30	
<b>457x890</b>	0.40	457x890	537x970	15.0	102.0	4	101.0	15.0	114.0	8	114.0	28	485.0	-	
<b>490x590</b>	0.28	485x585	565x665	17.5	90.0	5	114.0	17.5	90.0	6	90.0	26	332.5	-0.35	
<b>578x851</b>	0.47	560x845	658x931	22.7	102.3	5	102.0	16.1	99.4	8	100.0	30	465.5	-0.35	
<b>586x920</b>	0.53	581x915	661x995	12.5	68.0	6	100.0	12.5	85.0	9	100.0	34	447.5	-0.30	
<b>610x290</b>	0.17	605x285	365x685	11.5	114.0	2	114.0	12.5	110.0	5	110.0	18	397.5	-0.30	
<b>610x610</b>	0.37	610x610	690x690	15.0	110.0	5	110.0	15.0	110.0	5	110.0	24	400.0	-0.35	
<b>630x310</b>	0.19	625x305	385x705	16.0	118.0	2	117.0	16.5	112.0	5	112.0	18	408.5	-0.35	
<b>800x800</b>	0.64	800x800	880x880	15.0	95.0	7	110.0	15.0	95.0	7	110.0	32	495.0	-0.30	
<b>851x1162</b>	0.98	845x1162	931x1242	16.1	99.4	8	100.0	12.95	100.05	11	114.0	42	672.0	-0.30	
<b>915x1118</b>	1.01	910x1113	990x1193	12.5	82.5	9	100.0	12.5	111.5	10	105.0	42	596.5	-0.30	
<b>920x920</b>	0.84	915x915	995x995	12.5	85.0	9	100.0	12.5	85.0	9	100.0	40	447.5	-0.30	
<b>1020x1020</b>	1.01	1015x1015	1095x1095	12.5	107.0	9	107.0	12.5	107.0	9	107.0	40	597.5	-0.30	
<b>1130x1130</b>	1.28	1130x1130	1220x1220	20.0	90.0	11	100.0	20.0	90.0	11	100.0	48	660.0	-0.30	

<sup>1)</sup> Contact the manufacturer for more information.  
Use screws M10, flat washers M10 (ISO 7089) and nuts M10 (ISO 4032) to secure the VENT PRO S and comply with a tightening torque of 21Nm.  
The values of maximum vacuum are for VENT PRO S with a static opening pressure of 10 kPa.