

FLEX C PRO (S) - FLAMELESS EXPLOSION VENTING DEVICES



This is a safety device designed to relieve and release explosions developing inside a protected device that is in an explosive environment. In the event of an explosion, FLEX captures the explosive energy (flame, pressure) emerging from the open explosion relief device. Thanks to the special design of the flame filter, it cools the temperature of the flame and exhaust gases during the explosion to a level that is no longer dangerous to technology and to people in the proximity.

FLEX C PRO (S) consists of the VENT PRO explosion relief device and the welded FLEX body equipped with a two flame filters (C5 PRO with three flame filters). It is equipped with an opening indicator for electronic signaling of the VENT PRO breach.

This data sheet describes the technical parameters of the FLEX C PRO (S) device, which has a circular base. They are manufactured with the standard EN 16009 and European Directive 2014/34/EU.

FLEX CLASSIFICATION

Equipment group	II
Explosive atmosphere	D
Equipment category, indoor/outdoor	1 D 3G / 3G D
Zone	indoor 20
	outdoor 2, 22
Max. K_{st} - metallic dust	≤ 309 bar m/s
Max. K_{st} - non metallic dust	≤ 300 bar m/s
Ambient temperature	-40 °C to 60 °C
Operating temperature	-40 °C to 240 °C
Storage temperature	-10 °C to 40 °C
$P_{red,max}$	up to 1,9 bar

MATERIAL

Body	structural steel material with RAL 9005 (black) powder coated finish, other colors can be supplied depending on customer requirements
Flame filter	stainless steel
Explosion venting device	stainless steel it is also an integral part of FLEX, to which it is attached with adhesive, including the opening indicator
Flange gasket	EPDM supplied with FLEX
Fasteners	screws ISO 4017 – 8.8, nuts ISO 7040 – 8, washers ISO 7089 all is supplied with galvanized fasteners

OPTIONAL ACCESSORIES

Protective bag	it is used to cover the working surface of the FLEX flame filter to prevent foreign particles from entering the filter screens, it is recommended for use in dusty environments., In the event of an explosion, the bag will rupture and the energy absorption process will be uninterrupted
Intrinsically safe relay	it creates an interface between the safe and unsafe zone
Special flange gasket	in addition to the standard flange gasket, gaskets made from special materials precisely suited to the customer's specific application can also be provided

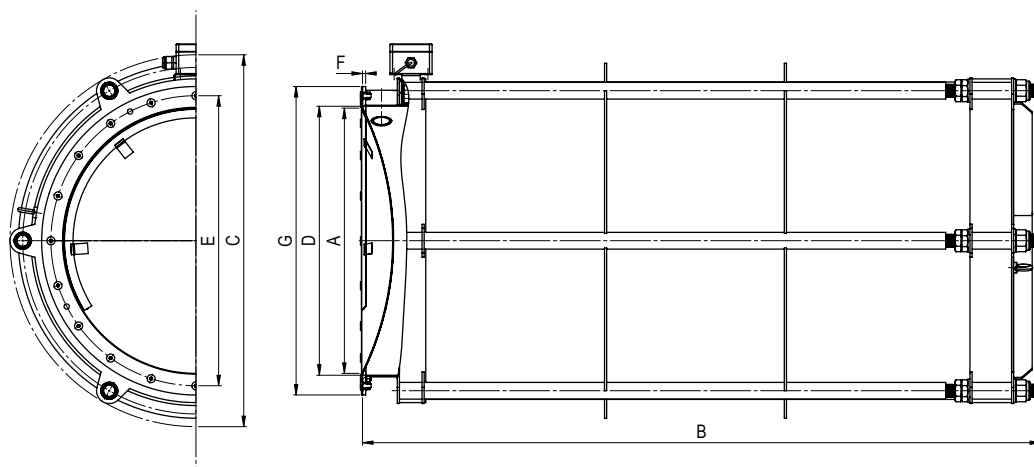
DIMENSIONS SCHEME

Type	Code	A [mm] [[in]]	B [mm] [[in]]	C [mm] [[in]]	D [mm] [[in]]	E [mm] [[in]]	F [mm]	G [mm] [[in]]	d - screw holes diameter [mm]	n - number of bolt holes [pcs.]	Weight [kg] [[lbs]]
FLEX C1 PRO	C-FLM-C1-VPT-10	315 (12,6)	580 (22,8)	485 (19,1)	320 (12,6)	350 (13,8)	5	375 (14,8)	10	12	45 (99)
FLEX C1 PRO S	C-FLM-C1-S-VPT-10	315 (12,6)	879 (34,6)	633 (24,9)	320 (12,6)	350 (13,8)	5	375 (14,8)	10	12	86 (190)
FLEX C2 PRO S	C-FLM-C2-S-VPT-10	445 (17,5)	1075 (42,3)	633 (24,9)	450 (17,7)	486 (19,1)	5	525 (20,7)	12	12	98 (216)
FLEX C3 PRO S	C-FLM-C3-S-VPT-10	505 (19,9)	1286 (50,6)	705 (27,8)	510 (20,1)	550 (21,7)	6	585 (23)	12	20	132 (291)
FLEX C4 PRO S	C-FLM-C4-S-VPT-10	625 (24,6)	1385 (54,5)	1020 (40,2)	630 (24,8)	680 (26,8)	6	705 (27,8)	12	20	236 (520)
FLEX C5 PRO	C-FLM-C5-VPT-10	815 (32,1)	2215 (87,2)	1020 (40,2)	820 (32,3)	860 (33,9)	6	895 (35,2)	12	24	360 (794)